

PATENT AGENT EXAMINATION, 2018

[Under Section 126 of Patent Act, 1970]

Paper II

Total Marks: 100

Time: 2.30 p.m. to 5.30 p.m. (Three Hours)

Instructions:

1. This paper consists of 3 parts –Part A (20 Marks), Part B(30 Marks) & Part C(50 Marks).
2. All questions in Part A and B are compulsory.
3. Part C comprises Part C1 of 20 Marks and C2 of 30 Mark. Part C1 consists of 2 questions and the candidate is required to answer any 1 of them, Part C2 consists of 2 questions and the candidate is required to answer any 1 of them.
4. In case a candidate answers more questions than required, the first attempted question shall be evaluated.
5. Candidates should read the questions very carefully before answering.
6. No clarification shall be provided during the course of the examination.
7. There is no negative marking.

PART A

4x5 Marks = 20 Marks (4 questions)

Q.1 Write a short note on Non patentable inventions within the provision of The Patent Act, 1970.

Q.2 A psychiatrist of Mumbai develops a music therapy for his schizophrenic patients which has tremendous impact on them and helps them to get rid of many of the symptoms of schizophrenia. The doctor attended one awareness program for patent filing and being motivated approached you for advice. As a registered Patent agent what do you suggest him?

Q.3 One client 'A' has come to your office for seeking advice regarding assignment for a "solar cooktop" which 'B' has already patented. As a practicing Patent Agent brief him about the applicable issues as per the Patent Act and Rules to your client A?

Q.4 The grant of Patent is based on certain conditions as stipulated in section 47 of The Patent Act. Briefly explain those conditions.

PART B

3X10M=30Marks (3 questions)

Q.5 Explain briefly the different Provisions of The Patent Act for the following:

- a. Role of a Patent Agent.
- b. Criteria for disqualification of Patent Agent.

Q.6 Explain the various provisions in the prevailing Patent Rules for 'Expedited Examination', 'Small entity' and 'Startup'.

Q.7 Mr. Dutta, a research scholar of an Indian University invented one watch which acts as an alarm for senior citizen and patients to respective call centers of registered hospitals for emergency support. In the meantime Mr. Dutta has approached Central government to approve a financial grant for his invention and had a discussion with concerned official of the said department. Mr. Dutta exhibited his invention in Industrial fair organized by Government in Pragati Maidan, Delhi on 15th February, 2015. One of his colleague in the same laboratory published his invention in leading newspaper on 2nd March, 2015 without his consent. Meanwhile, he has attended one awareness program on Patent in Delhi on 5th March 2015. Immediately on 10th March, 2015 he has filed a Provisional Specification before The Patent Office, Delhi and subsequently filed Complete Specification on 10th December, 2015. Mr. Dutta is not sure whether the exhibition and publication in newspaper or communication with Govt. official would hamper his patent protection or not, hence he seeks your advice. Give the appropriate advice in writings to your client as a practicing Patent Agent quoting the relevant sections of Patent Act, 1970.

PART C1

After reading the specification

- i. Provide an appropriate title
- ii. Draft an abstract (maximum of 150 words)
- iii. Draft at least two claims

1X20Marks =20Marks

Q.8

This invention relates to a garden sprinkler hose to deliver water to restricted areas and in selected directions. The extent of the area to which water is delivered by the hose is controlled by the water pressure. The objects of the invention are achieved by providing a hose construction which is generally triangular in transverse cross section, two of its three wall sections being relatively firm and thicker than its third wall section which is relatively thin and flexible. Only the flexible wall is provided with apertures for passage of water out of the hose. This invention permits either of the imperforate, firm relatively thick walls to serve as a base on which the hose may rest, while the flexible wall responds to water pressure in the hose by curving outwardly, causing the water streams to flow in predetermined directions and to cover lawn and garden areas to a selected extent. The hose may be placed adjacent a wall or sidewalk edge, with its flexible wall facing away from the wall or walk edge, to deliver water without waste to cover an area of selected width. In the drawings: FIG. 1 depicts a portion of a garden sprinkler hose embodying the invention. FIG. 2 is a transverse sectional view showing the hose as it appears when delivering water streams in response to limited water pressure in the hose. FIG. 3 is similar to FIG. 2 showing the hose as it appears when delivering water streams in response to increased water pressure in the hose as compared to FIG. 2. In the embodiment of the invention shown in the drawings, the hose comprises two imperforate, relatively firm and thick wall sections 11 and 12, either of which may provide a base on which the hose rests in use. The walls 11 and 12 are joined together at one of their longitudinal edges to extend at divergent angles. The other longitudinal edges of the walls 11 and 12 are joined to a relatively

thin and flexible wall 13 provided with apertures 14 for passage of water out of the hose. The junctions between each of the walls 11 and 12 and the flexible wall 13 are curved continuations of the flexible wall which merge into the thicker walls 11 and 12 as indicated at 15. The flexible wall 13 responds to the water pressure in the hose by curving outwardly to varying degrees, as illustrated in FIG. 2 where the water pressure is less than maximum, and in FIG. 3 where the water pressure has been increased as compared to FIG. 2. Thus the width of the area covered by the water is less in FIG. 2 than in FIG. 3, due to the degree of curvature of the wall 13. By placing the hose on either of its walls, 11 or 12, adjacent a wall or walk or patio edge, the water is directed away from the not-to-be watered area, and the extent of the area to be watered can be controlled as to direction and width. The hose may be made of rubber or any other suitable material which permits automatic curvature of the apertured wall in response to water pressure. The walls preferably are molded or formed integrally.

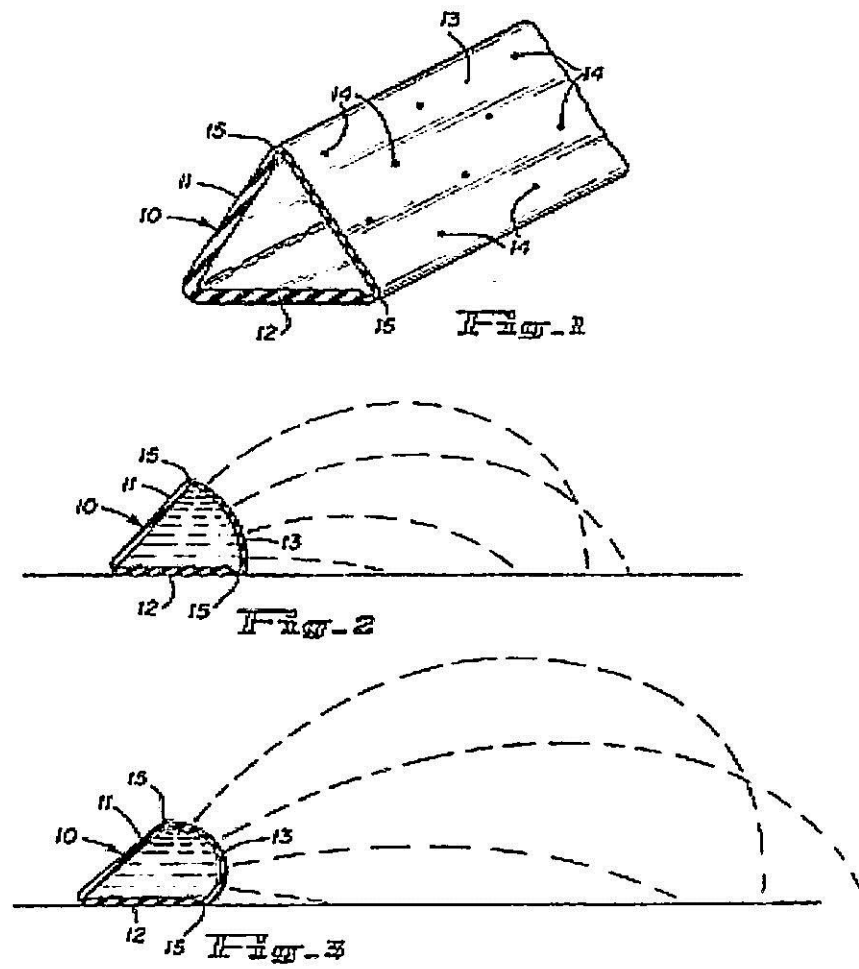

Or

Q. 9

This invention relates to a hair conditioning product and process for producing a hair conditioner capable of increasing the gloss, softness, elasticity, and the tendency to maintain the desirable shape of the hair. Hair conditioners improve sensibly the aspect and the physical form of the hair treated with them. There

exists a great variety of formulas for conditioning the hair. The available formulas leave much to be desired in the way of cost, ease of use and ingredients which may have an objectionable odor. Further, none of them attains the efficiency of the formulas and processes described in this invention. It is an object of the present invention to provide a hair conditioning product having a low price and a pleasant odor. Yet another object of this invention is to provide a hair conditioning product that is easy to use. Still another object of the present invention is to provide a hair conditioning product that enhances the natural shine and softness of the hair and which maintains the shape of the hair over extended periods of time. It is another object of the present invention to provide a product that can remain in contact with the hair for long periods of time without damage to the hair.

This invention relates to a hair conditioner and a process for producing an entirely new conditioner employing ascorbic acid and cupric and/or cuprous salts. Ascorbic acid is vitamin C, ($C_6H_8O_6$), found in many fruits, especially in the citric, and in some vegetables with green leaves. The hair conditioner, made accordingly to this process, is presented to the user packaged as powder, which besides the active ingredients (which bring about the desired effects), contains also a thickening agent. This powder is mixed with water by the user, before application. Another form of the conditioner from this invention is as a convenient gel, paste or cream, which is applied directly by the user who intends to shape his or her hair. The formulations of the present invention may also include, without altering the basic concepts of the present patent application: tensoactives, humectants, and their functional equivalents or similar, besides the other compounds used in the treatment of hair shaping and conditioning, like quaternary salts, certain dyes, relaxers, etc. In order to provide a perfect and complete idea of the invention, there will be presented some examples of formulations which can be realized to attain the objectives of this invention, that is to produce an efficient hair conditioner. The following is an example of formulation of the present invention.

EXAMPLE NO.1 - 1 g of cuprous chloride, 3 g of ascorbic acid, 5 g of ammonium chloride and 15 g of soluble starch are milled. The powder is mixed with water and applied to hair, which acquires permanent gloss, softness and elasticity noticeably superior to other conditioners used by present art.

EXAMPLE NO.2 - 0.5 g ammonium chloride are dissolved in 150 ml of water, 25 g of carboxymethylcellulose are added and the mixture agitated until obtaining a homogenous paste, which is applied to the hair. The gloss, softness and elasticity of the hair are superior to the results obtained with common conditioners on the market.

EXAMPLE NO.3 - 3 grams of pyrogallol, 1 g of cupric oxide, 12 ml of N-hydrochloric acid, 3 g of ascorbic acid, and 5 g of ammonium chloride are dissolved in 140 ml of water. 20 g of pre-gellified starch is added and agitated until homogenous. The hair which is treated with the resulting cream, after being washed and dried in the desired shape, undulated or stretched shows the characteristic gloss, softness and elasticity, besides maintaining permanently its shape. Independently from these results, the hair is also tinted by the dye precursor (pyrogallol) included in the formula.

EXAMPLE NO.4 - 1.6 g of pentahydrated cupric sulfate, 2.2 g of ascorbic acid, 1.3 g of ammonium chloride, and 35 g of sodium lauryl ether sulfate of 30% are dissolved in 60 ml of water. The solution, thus, obtained was used as conventional shampoo to wash hair. The washed hair, besides being clean, is glossy and soft and exhibits great tendency to keep permanently the shape in which it was dried.

PART C2

A Client meets you and provides technical information regarding his invention. Draft a complete specification with at least two claims and a title for the following description for filing before the Indian Patent office. While preparing the complete specification, do not redraw the figures, however you may refer to the figures in the specifications.

1x30Marks = 30marks

Q.10

This invention relates to apparatus and method for collecting liquids and, in particular, to liquid collection apparatus and methods of the type employed in printing devices to collect unused ink. Traditional liquid collection devices collect liquid (in the case of printing ink) for reuse in the process in which the liquid is being employed. Such liquid collection devices do, however, have problems associated with them. One significant problem is that air can be collected with the liquid and mixed with it by the collection device. The air can contain contaminants, which are drawn into the liquid, reducing the quality of the recycled liquid. A further problem, particular to printing inks, is that mixing of the inks with air can lead to ink solvent evaporation into the air, increasing the viscosity of the ink. The present invention is directed towards the provision of a liquid collection apparatus which collects liquid without collecting air trapped therein. According to the present invention there is provided a liquid collection apparatus comprising: means for collecting liquid; liquid conduit means for transferring liquid from the liquid collection means; porous liquid absorption means positioned between the liquid collection means and the liquid conduit; and pump means for pumping liquid from the liquid conduit, the pump means generating a pressure in liquid in the conduit that is sufficient to draw liquid through liquid collection means but is insufficient to draw a gas/liquid surface through the liquid absorption means. Because the pressure generated by the pump means is not sufficient to draw a gas/liquid surface through the porous liquid absorption means against surface tension forces in the absorption means, any gas contained within .The liquid will not be drawn through the liquid absorption means and into the liquid conduit. The apparatus may be arranged to be employed in an ink jet print head, in which case the liquid may be ink. The liquid absorption means may have pores of a diameter of one micron or less. The pore diameters may be in the range of 0.2 to 1 micron. Alternatively, it may be formed from a plurality of narrow capillaries. The material from which the liquid absorption means is formed will be dependent upon the type of liquid being collected, but may be formed from cellulose, nylon, mixed esters or polypropylene. The liquid collecting means may be arranged so that the surface of the liquid absorption means is not in direct contact with the atmosphere to reduce the possibility of liquid retained by the absorption means drying due to contact with the atmosphere. The liquid collection means may be formed from a plurality of ribs or of an absorbent material containing pores/capillaries of larger diameter than those in the liquid absorption means. Such an arrangement provides an apparatus which can be moved without liquid spilling out due to the effects of the motion and/or gravity. According to the present invention there is also provided a method of collecting liquid, the method comprising the steps of: collecting liquid in a liquid collection means; and drawing the liquid through a porous liquid absorption means at a pressure level which ensures liquid flow through the liquid collection means yet which is insufficient to draw liquid through the liquid absorption means. One example of the present invention will now be described with reference to the accompanying drawing, in which: Figure 1 shows a schematic diagram of a liquid collection apparatus according to the present invention. Referring to figure 1, a liquid collection apparatus according to the present invention

has a liquid collection means 1 in the form of a gutter. A conduit 2 is connected to a pump (not shown). Positioned between the liquid collection means 1 and conduit 2 is a liquid absorption means 3. This liquid absorption means 3, in this example has a structure which consists of a plurality of pores of a diameter of 1 micron or less. In operation, the pump is operated to draw liquid collected by the liquid collection means 1 through the liquid absorption means 3 and into the conduit 2. The strength of the pump is such that it creates a sufficient pressure differential across the liquid absorption means 3 to ensure liquid flow there through. The operation of the pump is controlled, however, such that it does not generate a sufficient pressure differential to draw the gas/liquid surface through the absorption means 3. This ensures that, if air or any gas is drawn into the liquid collection means 1 it is not drawn into the absorption means 3 because the constant presence of liquid at the interface between the liquid and the gas at the boundary 4 between the collection means 1 and liquid absorption means 3 prevents the gas being drawn into the conduit 2. As mentioned above, the material from which the porous liquid absorption means 3 is formed will be dependent upon the type of liquid being collected, and should be selected so that it does not react with the collection liquid. As also mentioned above, the liquid collection means may include a plurality of ribs 5 to retain the liquid in use, and prevent spillage. Alternatively, it may be formed from absorbent material (not shown) of a density lower than that of the absorption means 3. In this example, the arrangement shown is employed to collect ink from a continuous jet print head. It will be appreciated, however, that the collection device of the invention has applications in many other fields.

Fig. 1.

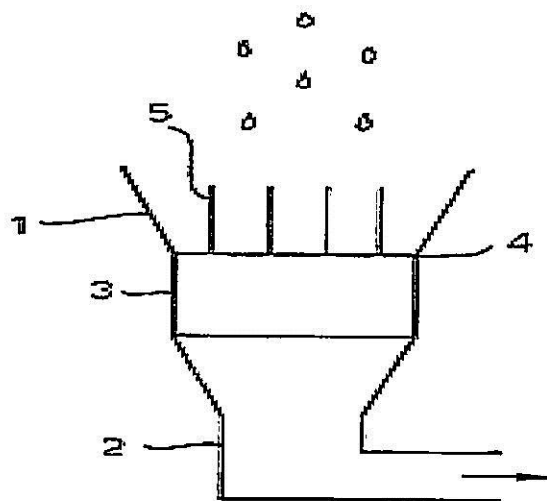

Or

Q.11

Noise filter such as herein disclosed is intended for use in desk computers, office machines and medical equipment and the like. Their main function of noise filter is the reduction of the line related noise levels. Since these filters, due to their application, are subjected to high electrical and magnetic field strength

levels because of the environment in which they operate, it must be ensured that their suppression effectiveness is not reduced through unintended coupling of electrical and magnetic interferences to the wiring or the components of the filter circuit. Especially when used in electrical equipment with combined power supplies and/or microprocessor systems which have long bus runs, these problems are encountered frequently. Such filters have become known, as example, as filters with integrated cold appliance plugs in which the connections from the net side are made via this cold appliance plug usually a so called power outlet and the contact to the equipment to be provided with the filter via flat plugs, soldering lugs. The terminals and the carriers of the electrical components are tightly cemented into a half round cup of nickel silver sheet. In this noise filter, the electrical components per se are mounted, insulated and manually soldered into the half round cup. Subsequently, the electrical components are fixed with a soft epoxy resin compound from the open side of the half round cup and then mechanically protected by a hard sealing compound. Other commercially available noise filters employ a deep-drawn nickel silver housing in place of the half round nickel silver cup. The components are then mounted and soldered in an auxiliary frame with flat plugs. Cementing the components and flat plug parts located in the filter housing is accomplished through a hole in the nickel silver housing which must be tightly sealed to plugs and frame by adding sealing rings. The cementing hole is covered up by a glued-on name plate.

Many noise filters also available in market a soldered jacket tube of tin plate, the electrical components being mounted to a base plate which is subsequently riveted to the plug. The ground connection is soldered on through a hole in the jacket tube which must be pushed over the plug first. The soldering point is covered up by a name plate. The electrical components are cemented in from the open backside of the jacket tube.

The noise filter according to FIG. 1, which shows a partially sectioned top view comprises of a filter housing 1, such as of extruded aluminum tubing, which is reduced in section at its one face 15 in the manner of a shaft and closed by a connector socket 2 at its other face. Inserted into the filter housing 1 is an insulating material housing 7 which may be subdivided, e.g. by separating walls not detailed, into chambers.

Mounted in these chambers are electrical components, e.g. an electrical resistor 3, not preassembled electrical capacitors 4, 5 Y-capacitors 12, 13, and a radio noise suppression inductor 6 slid on a potential separating web 8 which is integrally molded to the insulating material housing 7. As shown in partial sectioned view in FIG. 2, the winding ends 31-34 of the inductor 6 are wound around appropriately bent ends of flat plugs 10, 11, 19, 20 are soldered. The same applies to the capacitors 4, 5 and 12, 13 of FIG. 2 which are connected to the appropriate ends of the flat plugs via webs 21, 22, 23, 24. To the face area of the insulating material housing 7 facing the face end 15 is integrally molded a shaft 14 whose outside surfaces rest against the inside surfaces of the filter housing. The electrical components and the flat plugs 10, 11, 19, 20 connected to these components are embedded in epoxy resin 30, only the outwardly facing parts of the flat plugs being left free.

A grounded conductor 9 is provided, extending over the entire length of the insulating material housing 7. For contact between this ground wire and the filter housing a copper plate is welded ultrasonically to the filter housing 1 in the area where the ground wire penetrates the face wall of filter housing 1. The direct contact between ground wire 9 and this copper plate is established by the solder point indicated at 16.

The Y-capacitors 12, 13 are disposed directly between phase and ground wire housing and contacted to the ground wire at 18. A very low inductance connection is obtained by these extremely short leads. In FIG. 3, a sectional view as indicated in FIG. 2, the organization of internal components of the filter is illustrated. The short lead connections for the Y-capacitors 12 and 13 are clearly illustrated connecting respectively between flat plugs 11 and 12 and grounded connector 9.

FIG 1

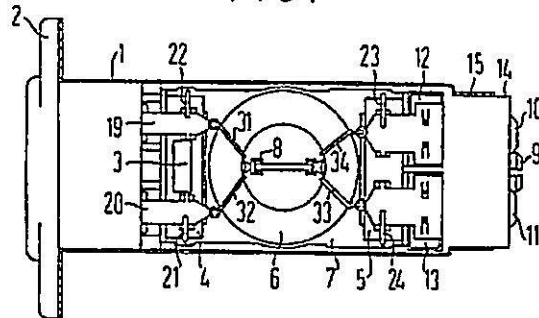

FIG 2

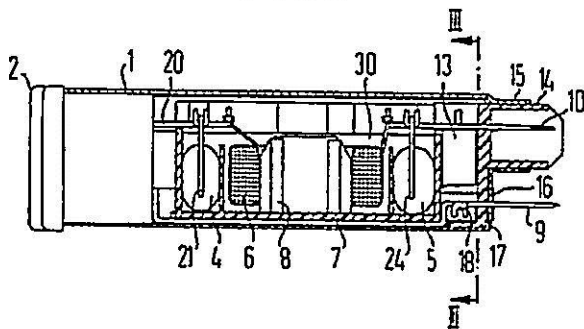
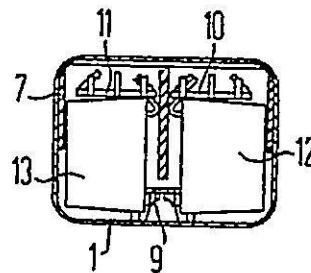

FIG 3



- END -